

Pulsation Dampener

Model: AD-40ST-FDA
Model #: 853372-FDA



To Purchase:

- 800-990-7867
- sales@yamadapump.com
- Find My Rep

More Information:

- YouTube: @yamadapump
- yamadapump.com
- Data Sheets | CAD Drawings | Manuals Literature | BOM | Performance Curves

Trial Program

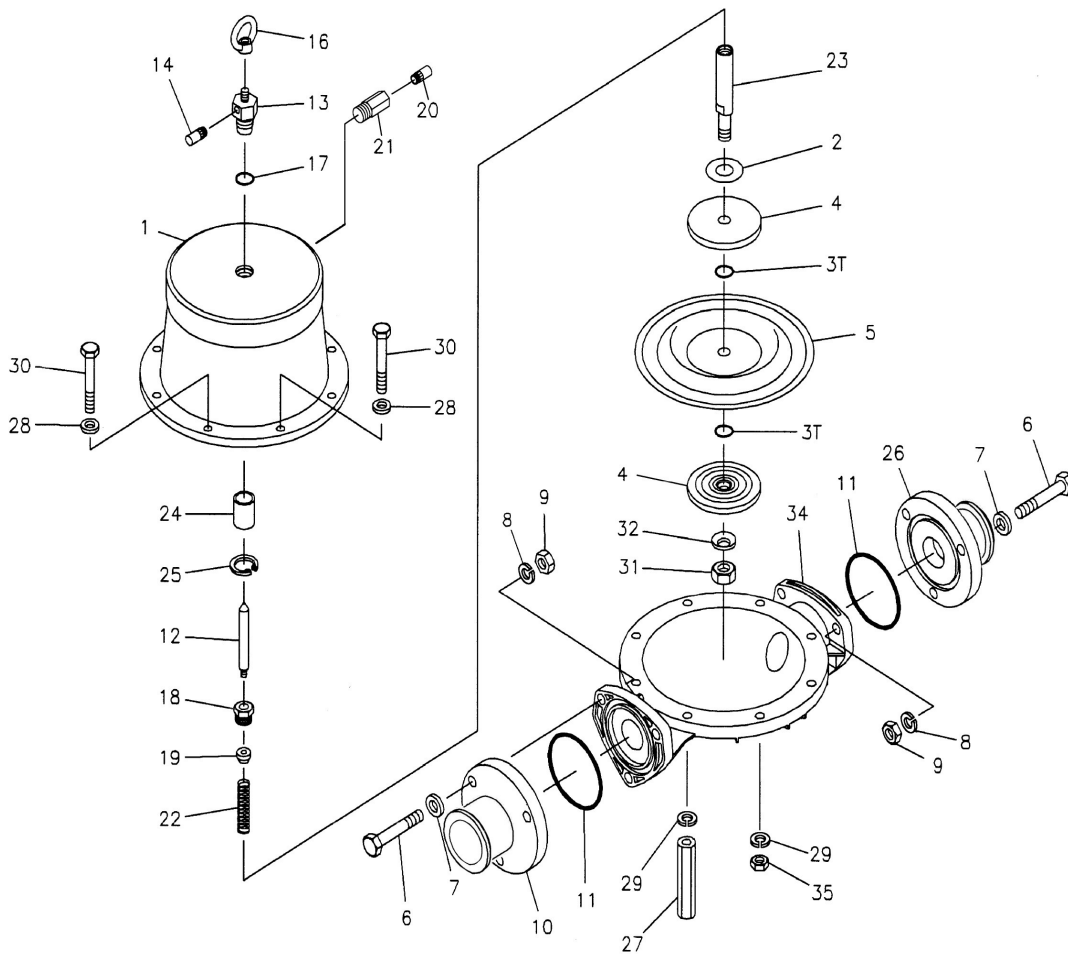

Pulsation Dampener

REF. NO.	PART NO.	DESCRIPTION	QTY.	REORDER
1	713306-XP	AIR CHAMBER	1	
2	771316	CUSHION	1	
3T	643015	O-RING	2	
4	707817	CENTER DISK	1	
5	770814	DIAPHRAGM	1	
6	621204	BOLT	6	
7	631175	WASHER FLAT	6	
8	631938	WAVE WASHER	6	
9	628014	NUT	6	
10	714094-TC-EP	FLANGE OUT	1	
11	643065	O-RING	2	
12	795080	VALVE	1	
13	716407	VALVE SEAT	1	
14	802569	SILENCER ASSY	1	
16	630241	EYE BOLT	1	
17	640017	O-RING	1	
18	710717	NUT	1	
19	710719	NUT	1	
20	681170	SILENCER	1	
21	714085	UNION	1	
22	710727	SPRING	1	
23	713295	CENTER ROD	1	
24	773092	THROAT BEARING	1	
25	630807	STOP RING	1	
26	714093-TC-EP	FLANGE IN	1	
27	713316	STUD	4	
28	631174	WASHER FLAT	8	
29	631937	WAVE WASHER	8	
30	621181	BOLT	8	
31	706128	NUT	1	
32	682740	WASHER	1	
33	707818-EP	CENTER DISK	1	
34	712931-EP	OUT CHAMBER	1	
35	628013	NUT	4	

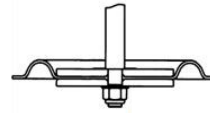

Installation direction of diaphragm.

Torque Values:

Valve (#12)	6 ft-lbf (10N-m)
Center Rod (#23)	44 ft-lbf (60N-m)
Bolt (out chamber #6)	29 ft-lbf (40N-m)

General Tools:

- Socket wrenches - 17mm, 24mm
- Box wrench - 17mm
- Pliers
- Adjustable angle wrench
- Flat-head screwdriver

Special Tools (optional):

- Socket (804131) to remove spring sheet.
- Tweezers (713148) to remove sleeve.

Miscellaneous:

- Urea grease grade (NLGI) No. 2
- Thread locking agent

Customer Notes

Model #: _____
 Description: _____
 Serial #: _____
 Date Installed: _____
 Department Location: _____
 Tag/Project: _____