

Pulsation Dampener

Model: AD-40SH-FDA
Model #: 853373-FDA



To Purchase:

- ☎ 800-990-7867
- ✉ sales@yamadapump.com
- 📍 Find My Rep

More Information:

- ▶ YouTube: @yamadapump
- 🌐 yamadapump.com
- Data Sheets | CAD Drawings | Manuals Literature | BOM | Performance Curves*

Trial Program

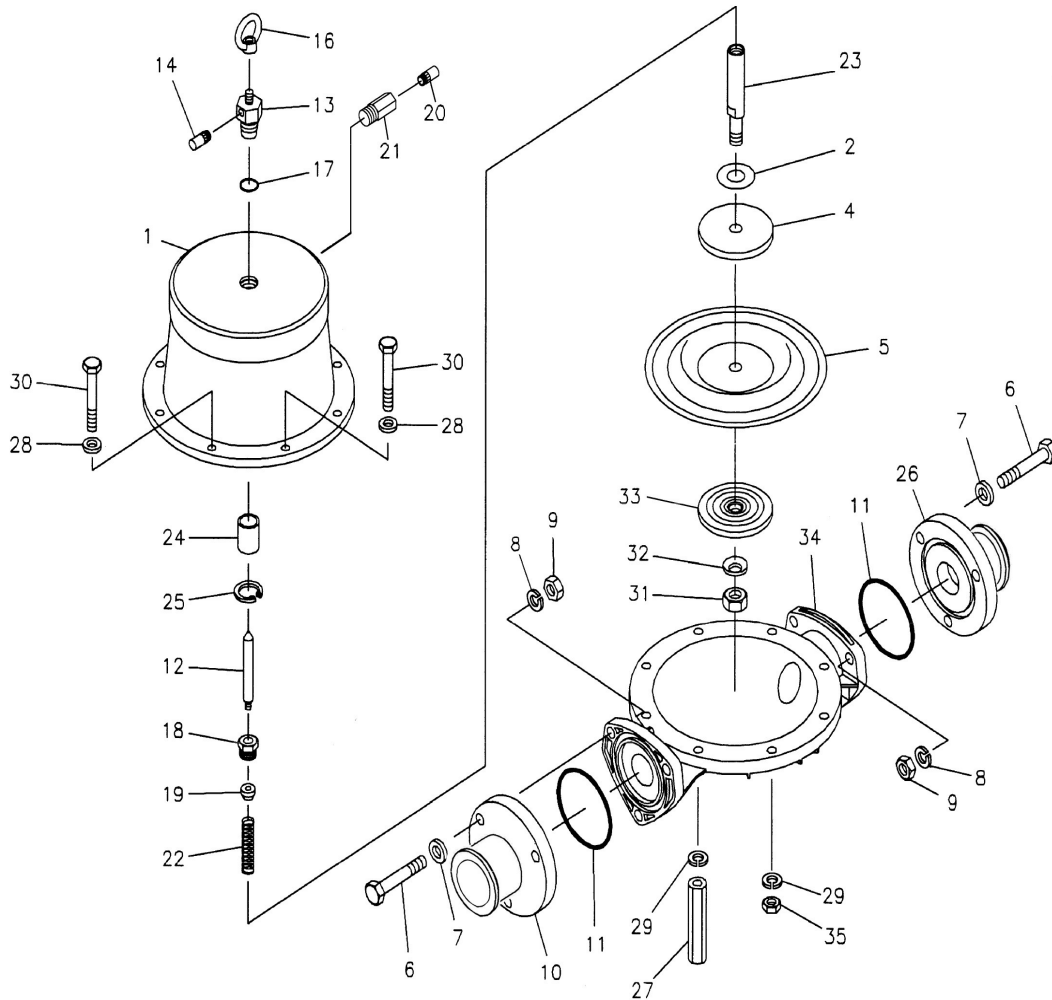

Pulsation Dampener

| REF. NO. | PART NO. | DESCRIPTION | QTY. | REORDER |
|----------|--------------|----------------|------|---------|
| 1 | 713306-XP | AIR CHAMBER | 1 | |
| 2 | 771316 | CUSHION | 1 | |
| 4 | 711902 | CENTER DISK | 1 | |
| 5 | 771701 | DIAPHRAGM | 1 | |
| 6 | 621204 | BOLT | 6 | |
| 7 | 631175 | WASHER FLAT | 6 | |
| 8 | 631938 | WAVE WASHER | 6 | |
| 9 | 628014 | NUT | 6 | |
| 10 | 714094-TC-EP | FLANGE OUT | 1 | |
| 11 | 643065 | O RING | 2 | |
| 12 | 795080 | VALVE | 1 | |
| 13 | 716407 | VALVE SEAT | 1 | |
| 14 | 802569 | SILENCER ASSY | 1 | |
| 16 | 630241 | EYE BOLT | 1 | |
| 17 | 640017 | O RING | 1 | |
| 18 | 710717 | NUT | 1 | |
| 19 | 710719 | NUT | 1 | |
| 20 | 681170 | SILENCER | 1 | |
| 21 | 714085 | UNION | 1 | |
| 22 | 710727 | SPRING | 1 | |
| 23 | 713442 | CENTER ROD | 1 | |
| 24 | 773092 | THROAT BEARING | 1 | |
| 25 | 630807 | STOP RING | 1 | |
| 26 | 714093-TC-EP | FLANGE IN | 1 | |
| 27 | 713316 | STUD | 4 | |
| 28 | 631174 | WASHER FLAT | 8 | |
| 29 | 631937 | WAVE WASHER | 8 | |
| 30 | 621181 | BOLT | 8 | |
| 31 | 683408 | NUT | 1 | |
| 32 | 682740 | WASHER FLAT | 1 | |
| 33 | 711903-EP | CENTER DISK | 1 | |
| 34 | 712931-EP | OUT CHAMBER | 1 | |
| 35 | 628013 | NUT | 4 | |

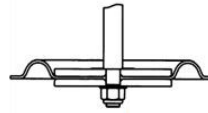

Installation direction of diaphragm.

Torque Values:

| | |
|-----------------------|-------------------|
| Valve (#12) | 6 ft-lbf (10N-m) |
| Center Rod (#23) | 44 ft-lbf (60N-m) |
| Bolt (out chamber #6) | 29 ft-lbf (40N-m) |

General Tools:

- Socket wrenches - 17mm, 24mm
- Box wrench - 17mm
- Pliers
- Adjustable angle wrench
- Flat-head screwdriver

Special Tools (optional):

- Socket (804131) to remove spring sheet.
- Tweezers (713148) to remove sleeve.

Miscellaneous:

- Urea grease grade (NLGI) No. 2
- Thread locking agent

Customer Notes

Model #: _____
 Description: _____
 Serial #: _____
 Date Installed: _____
 Department Location: _____
 Tag/Project: _____