

Pulsation Dampener



To Purchase:

- 800-990-7867
- sales@yamadapump.com
- Find My Rep

More Information:

- YouTube: @yamadapump
- yamadapump.com
- Data Sheets | CAD Drawings | Manuals Literature | BOM | Performance Curves

Trial Program



| REF. NO. | PART NO. | DESCRIPTION | QTY. | REORDER |
|----------|----------|---------------|------|---------|
| 1 | 681293 | MUFFLER | 1 | |
| 3 | 713208 | UNION | 1 | |
| 4 | 711151 | PLATE | 1 | |
| 5 | 771458 | AIR CHAMBER A | 1 | |
| 6 | 640015 | O RING | 1 | |
| 7 | 711193 | SPRING | 1 | |
| 8 | 640003 | O RING | 1 | |
| 9 | 711152 | VALVE | 1 | |
| 10 | 831582 | THROTTLE | 1 | |
| 11 | 711150 | ROD | 1 | |
| 12 | 643080 | O RING | 2 | |

| REF. NO. | PART NO. | DESCRIPTION | QTY. | REORDER |
|----------|----------|-------------------|------|---------|
| 13 | 711149 | CENTER DISK | 1 | |
| 14 | 771459 | AIR CHAMBER B | 1 | |
| 15 | 771457 | DIAPHRAGM | 1 | |
| 16 | 772044 | OUT CHAMBER | 1 | |
| 17 | 711148 | PLATE | 1 | |
| 18 | 771644 | CAP | 12 | |
| 19 | 711154 | BASE | 2 | |
| 20 | 683636 | NUT | 12 | |
| 21 | 681303 | CONED DISC SPRING | 48 | |
| 22 | 711147 | TIE ROD | 6 | |

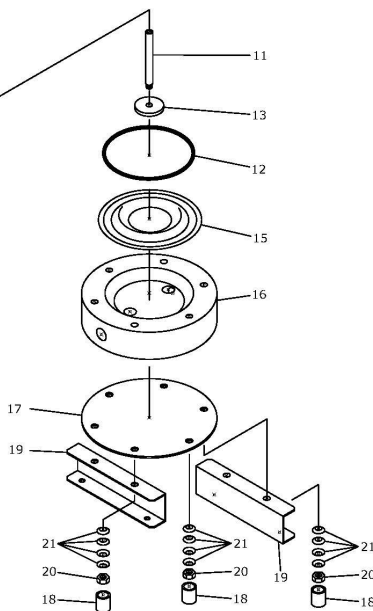
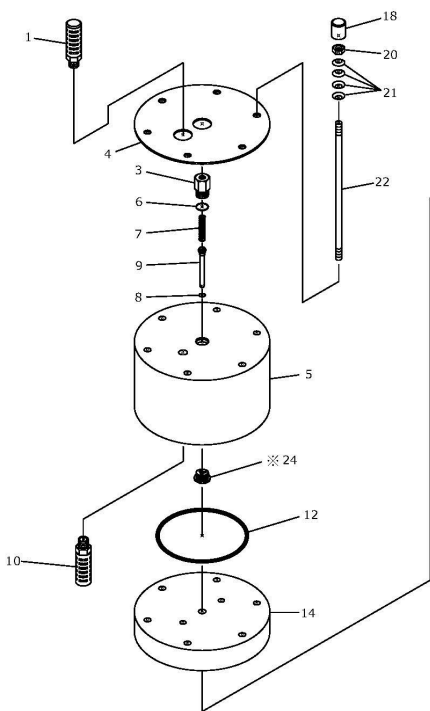

General Tools:

- Socket wrench - 17mm
- Box wrench - 17mm
- Adjustable angle wrenches
- Flat-blade screwdriver

Special Tools:

- Socket for guide (804131)
- Sleeve remover (713148)

Miscellaneous:

- Grease - Urea grease (NLGI) No. 2 or equivalent
- Grease - Fomblin® AR555 or equivalent
- Thread locking agent - Equivalent to Loctite® 222

Torque:

Tie Rods 80 in-lbf {10N-m}

Customer Notes

Model #: _____
 Description: _____
 Serial #: _____
 Date Installed: _____
 Department Location: _____
 Tag/Project: _____