

EXPLODED VIEW & PARTS LISTING

Air Operated Double Diaphragm Pump

Model: NDP-80 Stainless Steel-HP
High Pressure Pumps



To Purchase:

- ☎ 800-990-7867
- ✉ sales@yamadapump.com
- 📍 Find My Rep

More Information:

- ▶ YouTube: @yamadapump
- 🌐 yamadapump.com
- Data Sheets | CAD Drawings | Manuals Literature | BOM | Performance Curves*

Trial Program

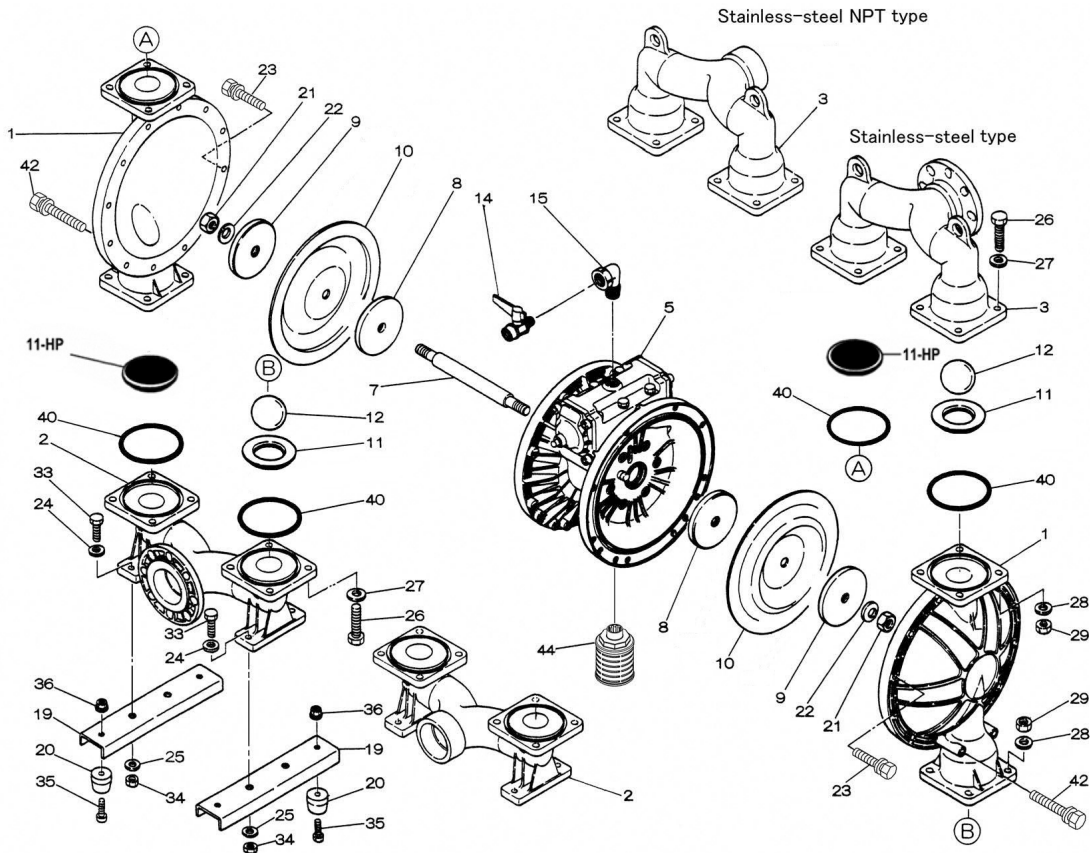

Air Operated Double Diaphragm Pump

■ Body Assembly

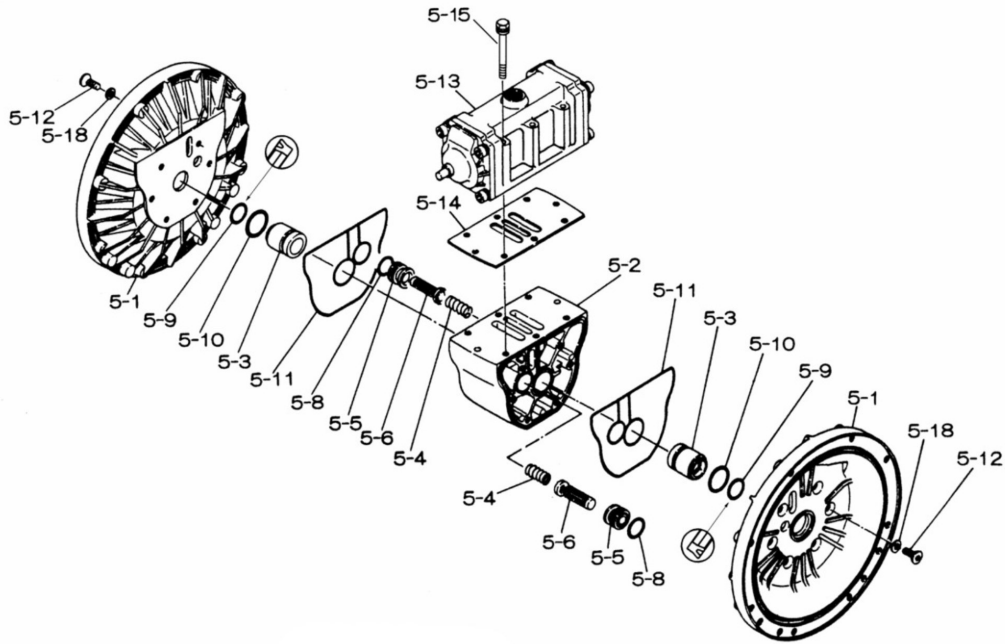

■ Valve Body Assembly

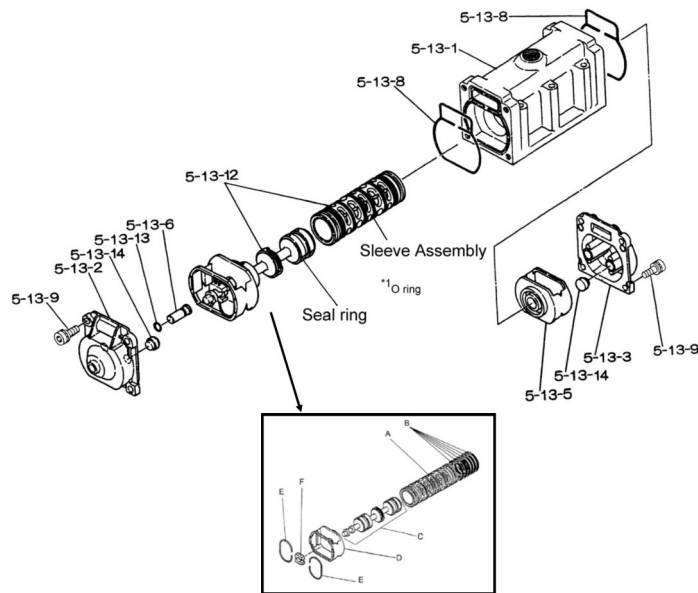

Air Operated Double Diaphragm Pump

	NDP-80BSC-HP	NDP-80BSN-HP	NDP-80BSE-HP	NDP-80BSV-HP	NDP-80BSH-HP	NDP-80BSS-HP	HIGH-PRESSURE PUMPS		
NPT	852653-HP	852649-HP	852654-HP	852652-HP	852650-HP	852728-HP	** NPT PUMPS **		
FLANGE	852431-HP	852241-HP	852432-HP	852307-HP	852242-HP	852726-HP	** FLANGE PUMPS **		
REF No.	PART No.	PART No.	PART No.	PART No.	PART No.	PART No.	DESCRIPTION	QTY.	REORDER
1	712933	712933	712933	712933	712933	712933	OUT CHAMBER	1	
1-HP	712933-HP	712933-HP	712933-HP	712933-HP	712933-HP	712933-HP	OUT CHAMBER-HP	1	
2	712603	712603	712603	712603	712603	712603	IN MANIFOLD - FLANGE	1	
2	712605	712605	712605	712605	712605	712605	IN MANIFOLD - NPT	1	
3	712602	712602	712602	712602	712602	712602	OUT MANIFOLD - FLANGE	1	
3	712904	712904	712904	712904	712904	712904	OUT MANIFOLD - NPT	1	
5	803113-HP	803113-HP	803113-HP	803113-HP	803113-HP	803113-HP	BODY ASSEMBLY	1	
5-1	711934	711934	711934	711934	711934	711934	AIR CHAMBER	2	
5-2	711936-HP	711936-HP	711936-HP	711936-HP	711936-HP	711936-HP	BODY	1	
5-3	772689	772689	772689	772689	772689	772689	THROAT BEARING	2	
5-4	711937	711937	711937	711937	711937	711937	SPRING	2	
5-5	771740	771740	771740	771740	771740	771740	VALVE SEAT	2	
5-6	832162	832162	832162	832162	832162	832162	PILOT VALVE ASSY.	2	
5-8	640020	640020	640020	640020	640020	640020	O-RING	2	
5-9	685444	685444	685444	685444	685444	685444	PACKING	2	
5-10	640029	640029	640029	640029	640029	640029	O-RING	2	
5-11	771742	771742	771742	771742	771742	771742	GASKET	2	
5-12	683812	683812	683812	683812	683812	683812	FLAT HEAD BOLD	12	
5-13	802971	802971	802971	802971	802971	802971	VALVE BODY ASSY.	1	
5-13-1	711931	711931	711931	711931	711931	711931	VALVE BODY	1	
5-13-2	580999	580999	580999	580999	580999	580999	CAP A	1	
5-13-3	581000	581000	581000	581000	581000	581000	CAP B	1	
5-13-5	771735	771735	771735	771735	771735	771735	SPRING STOPPER	1	
5-13-6	712976	712976	712976	712976	712976	712976	RESET BUTTON	1	
5-13-8	771738	771738	771738	771738	771738	771738	GASKET	2	
5-13-9	685036	685036	685036	685036	685036	685036	BOLT	8	
5-13-12	805084	805084	805084	805084	805084	805084	C-SPOOL VALVE ASSY.	1	
5-13-12 *1	803675	803675	803675	803675	803675	803675	SLEEVE ASSY.	1	
5-13-13	640005	640005	640005	640005	640005	640005	O-RING	1	
5-13-14	684128	684128	684128	684128	684128	684128	CUSHION	4	
5-14	771712	771712	771712	771712	771712	771712	GASKET	1	
5-15	684240	684240	684240	684240	684240	684240	BOLT	6	
5-18	684987	684987	684987	684987	684987	684987	PLAIN WASHER	12	
7	711901	711901	711901	711901	711901	711901	CENTER ROD	1	
8	711906	711906	711906	711906	711906	711906	CENTER DISK	2	
9	711907	711907	711907	711907	711907	711907	CENTER DISK	2	
10	771857	771704	771858	771801	771705	771977	DIAPHRAGM	2	
11	771958	771996	771999	771998	771795	772005	VALVE SEAT	2	
11-HP	711910-HP	711910-HP	711910-HP	711910-HP	711910-HP	711910-HP	VALVE SEAT-HP	2	
12	770559	770587	770596	770605	770587	770596	BALL	2	
14	684322	684322	684322	684322	684322	684322	BALL VALVE	1	
15	682523	682523	682523	682523	682523	682523	ELBOW	1	
19	711912	711912	711912	711912	711912	711912	PUMP BASE	2	
20	771402	771402	771402	771402	771402	771402	CUSHION	4	
21	683408	683408	683408	709144	683408	683408	NUT	2	
22	682740	682740	682740	682740	682740	682740	CONED DISK SPRING	2	

Air Operated Double Diaphragm Pump

	NDP-80BSC-HP	NDP-80BSN-HP	NDP-80BSE-HP	NDP-80BSV-HP	NDP-80BSH-HP	NDP-80BSS-HP	HIGH-PRESSURE PUMPS		
NPT	852653-HP	852649-HP	852654-HP	852652-HP	852650-HP	852728-HP	** NPT PUMPS **		
FLANGE	852431-HP	852241-HP	852432-HP	852307-HP	852242-HP	852726-HP	** FLANGE PUMPS **		
REF No.	PART No.	PART No.	PART No.	PART No.	PART No.	PART No.	DESCRIPTION	QTY.	REORDER
23	621182	621182	621182	621182	621182	621182	BOLT	16	
	631937	631937	631937	631937	631937	631937	WAVE SPRING WASHER	16	
24	631174	631174	631174	631174	631174	631174	PLAIN WASHER	4	
25	631937	631937	631937	631937	631937	631937	WAVE SPRING WASHER	4	
26	621203	621203	621203	621203	621203	621203	BOLT	12	
27	631175	631175	631175	631175	631175	631175	PLAIN WASHER	12	
28	631938	631938	631938	631938	631938	631938	WAVE SPRING WASHER	12	
29	628014	628014	628014	628014	628014	628014	NUT	12	
33	621177	621177	621177	621177	621177	621177	BOLT	4	
34	628013	628013	628013	628013	628013	628013	NUT	4	
35	611149	611149	611149	611149	611149	611149	BOLT	4	
36	682276	682276	682276	682276	682276	682276	NUT W/FLANGE	4	
40	640078	640078	684124	642078	640078	684124	O-RING	4	
42	686164	686164	686164	686164	686164	686164	BOLT	4	
	631917	631917	631917	631917	631917	631917	WASHER	4	
44	804764	804764	804764	804764	804764	804764	MUFFLER	1	
KIT		K80-AM					AIR MOTOR KIT		

Not Shown: Hose Assembly with Fittings

General Tools:

- Socket wrench - 13mm, 17mm, 19mm, 24mm
- Hexagonal box wrench - 5mm, 6mm
- Small crowbars—2 (C/N/E/V)
- Open-end wrench - 19mm, 24mm
- Plastic hammer

Special Tools (sold separately):

- Sleeve remover (713180) used for removing the sleeve

Miscellaneous:

- Assembly Oil - Turbine oil none additional class 1 (equivalent to ISO VG32 grade)
- Nuts - M16 x 1.5
- Thread Locker
- Urea grease grade (NLGI) No. 2

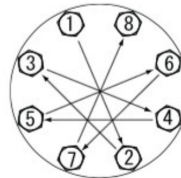

Tightening torque for center rod and out chambers.

Center Rod 43 ft-lbf {60 N-m}
Out Chambers 29 ft-lbf {40 N-m}

Tightening torque for manifold retainer bolts.

BAC/N/E/V/H/S-HP 18 ft-lbf {25 N-m}

Customer Notes

Model #: _____
 Description: _____
 Serial #: _____
 Date Installed: _____
 Department Location: _____
 Tag/Project: _____