

EXPLODED VIEW & PARTS LISTING

Air Operated Double Diaphragm Pump

Model: NDP-80BF[x]-BH2
CAST IRON POWDER PUMP
(rubber fitted)



To Purchase:

- 800-990-7867
- sales@yamadapump.com
- Find My Rep

More Information:

- YouTube: @yamadapump
- yamadapump.com
- Data Sheets | CAD Drawings | Manuals Literature | BOM | Performance Curves

Trial Program

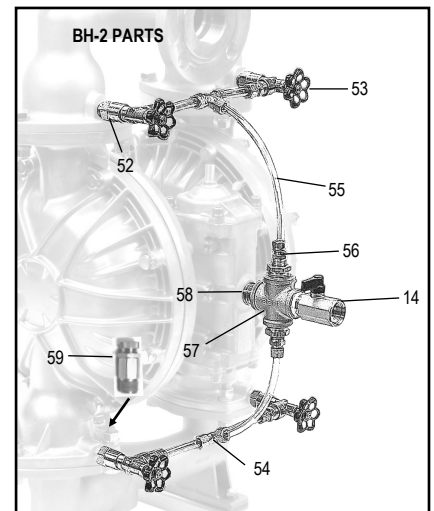
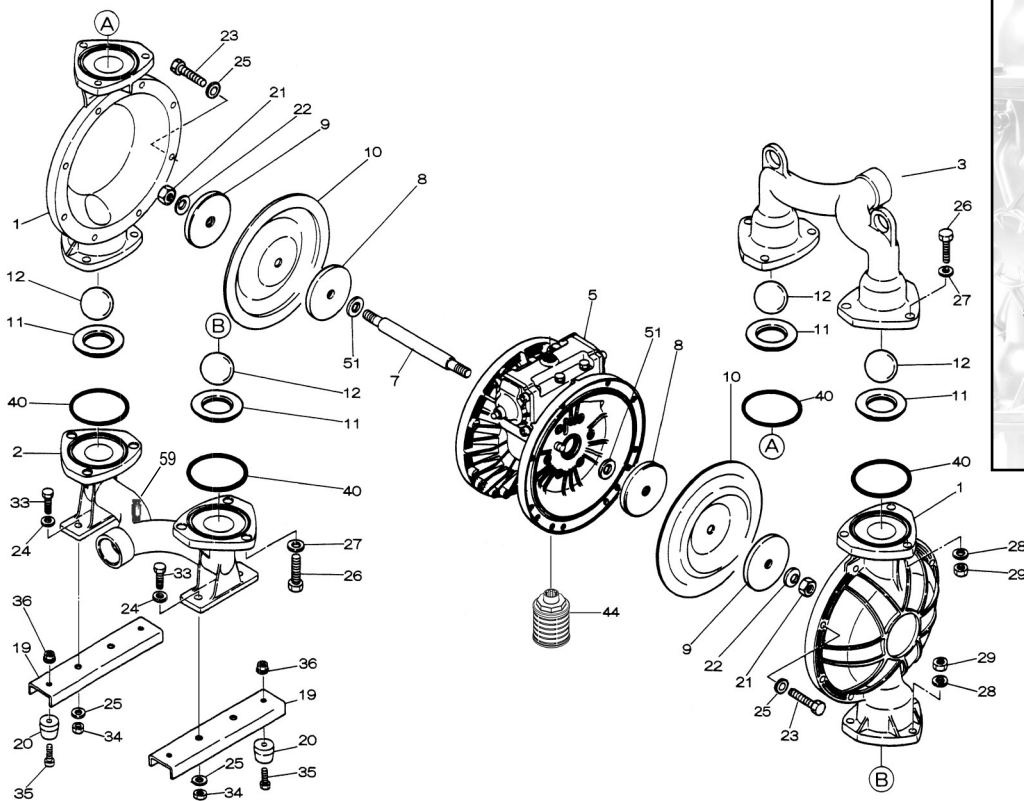

■Body Assembly



■Valve Body Assembly

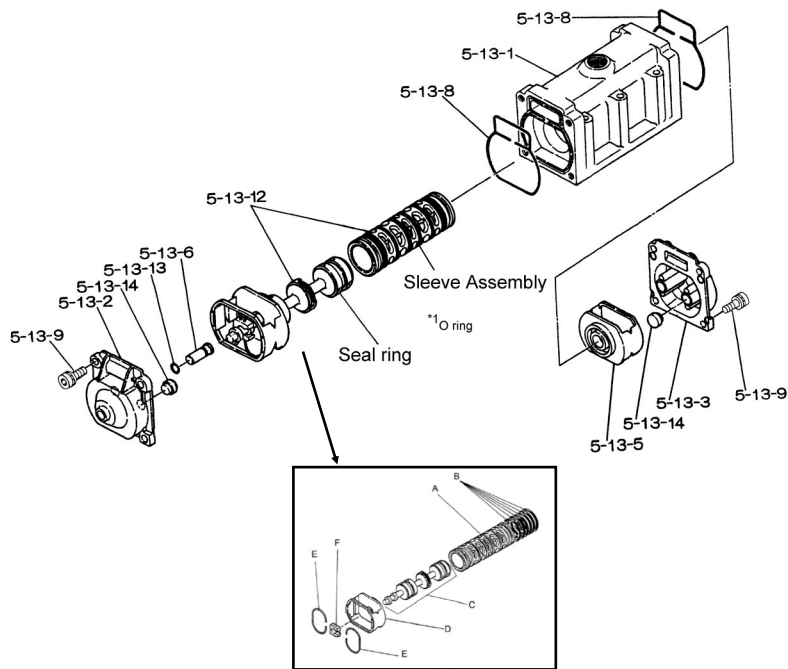



Air Operated Double Diaphragm Pump

	NDP-80BFC-BH-2	NDP-80BFN-BH-2	NDP-80BFE-BH-2	NDP-80BFH-BH-2	NDP-80BFS-BH-2	NDP-80BFV-BH-2	POWDER PUMPS		
	852859-BH-2	852855-BH-2	852860-BH-2	852856-BH-2	852861-BH-2	852858-BH-2			
REF. No.	PART No.	PART No.	PART No.	PART No.	PART No.	PART No.	DESCRIPTION	QTY.	REORDER
1	713158	713158	713158	713158	713158	713158	OUT CHAMBER - BH	2	
2	714370	714370	714370	714370	714370	714370	IN MANIFOLD - BH	1	
3	714367	714367	714367	714367	714367	714367	OUT MANIFOLD - BH	1	
5	803113	803113	803113	803113	803113	803113	BODY	1	
5-1	711935	711935	711935	711935	711935	711935	AIR CHAMBER	2	
5-2	711936	711936	711936	711936	711936	711936	BODY	1	
5-3	780325	780325	780325	780325	780325	780325	THROAT BEARING	2	
5-4	711937	711937	711937	711937	711937	711937	PILOT VALVE SPRING	2	
5-5	771740	771740	771740	771740	771740	771740	PILOT VALVE SEAT	2	
5-6	832162	832162	832162	832162	832162	832162	PILOT VALVE ASSY	2	
5-8	640020	640020	640020	640020	640020	640020	O RING	2	
5-9	685444	685444	685444	685444	685444	685444	V-PACKING	2	
5-10	640029	640029	640029	640029	640029	640029	O RING	2	
5-11	771742	771742	771742	771742	771742	771742	GASKET	2	
5-12	683812	683812	683812	683812	683812	683812	FLAT SOCKET	12	
5-13	802971	802971	802971	802971	802971	802971	VALVE BODY ASSY	1	
5-13-01	711931	711931	711931	711931	711931	711931	VALVE BODY	1	
5-13-02	580999	580999	580999	580999	580999	580999	CAP A	1	
5-13-03	581000	581000	581000	581000	581000	581000	CAP B	1	
5-13-05	771735	771735	771735	771735	771735	771735	SPRING RETAINER	1	
5-13-06	712976	712976	712976	712976	712976	712976	RESET BUTTON	1	
5-13-08	771738	771738	771738	771738	771738	771738	GASKET	2	
5-13-09	685036	685036	685036	685036	685036	685036	SOCKET BOLT	8	
5-13-12	805084	805084	805084	805084	805084	805084	C SPOOL ASSY	1	
A	803675	803675	803675	803675	803675	803675	SLEEVE ASSY	1	
B	640036	640036	640036	640036	640036	640036	O RING	6	
C	805085	805085	805085	805085	805085	805085	SPOOL ASSY	1	
D	771735	771735	771735	771735	771735	771735	SPRING RETAINER	1	
E	711932	711932	711932	711932	711932	711932	C SPRING	2	
F	771734	771734	771734	771734	771734	771734	BLOCK	1	
5-13-13	640005	640005	640005	640005	640005	640005	O RING	1	
5-13-14	684128	684128	684128	684128	684128	684128	CUSHION	4	
5-14	771712	771712	771712	771712	771712	771712	GASKET	1	
5-15	684240	684240	684240	684240	684240	684240	BOLT W/WASHERS	6	
5-18	683987	683987	683987	683987	683987	683987	WASHER	12	
7	711901	711901	711901	711901	711901	711901	CENTER ROD	1	
8	711906	711906	711906	711906	711906	711906	CENTER DISK	2	
9	713371	713371	713371	713371	713371	713371	CENTER DISK	2	
10	771857	771704	771858	771705	771977	771801	DIAPHRAGM	2	
11	771958	771996	771799	771795	772005	771998	VALVE SEAT	4	
12	770559	770587	770596	773144	773174	770605	BALL	4	
14	686974	686974	686974	686974	686974	686974	BALL VALVE	1	
15	682523	682523	682523	682523	682523	682523	ELBOW	1	
19	711912	711912	711912	711912	711912	711912	BASE	2	
20	771402	771402	771402	771402	771402	771402	FOOT RUBBER	4	
21	682740	682740	682740	682740	682740	682740	NUT	2	
22	682740	682740	682740	682740	682740	682740	WASHER	2	
23	631917	631917	631917	631917	631917	631917	WAVE WASHER	20	
23	686161	686161	686161	686161	686161	686161	BOLT	20	
24	631014	631014	631014	631014	631014	631014	FLAT WASHER	4	
25	631937	631937	631937	631937	631937	631937	WAVE WASHER	20	
26	611204	611204	611204	611204	611204	611204	BOLT	12	
27	631015	631015	631015	631015	631015	631015	FLAT WASHER	12	
28	631918	631918	631918	631918	631918	631918	WAVE WASHER	12	
29	627014	627014	627014	627014	627014	627014	NUT	12	
33	611177	611177	611177	611177	611177	611177	BOLT	4	
34	627013	627013	627013	627013	627013	627013	NUT	4	
35	611149	611149	611149	611149	611149	611149	BOLT	4	

Air Operated Double Diaphragm Pump (rubber fitted)

	NDP-80BFC-BH-2	NDP-80BFN-BH-2	NDP-80BFE-BH-2	NDP-80BFH-BH-2	NDP-80BFS-BH-2	NDP-80BFV-BH-2	POWDER PUMPS		
	852859-BH-2	852855-BH-2	852860-BH-2	852856-BH-2	852861-BH-2	852858-BH-2			
REF. No.	PART No.	PART No.	PART No.	PART No.	PART No.	PART No.	DESCRIPTION	QTY.	REORDER
36	682276	682276	682276	682276	682276	682276	NUT W/FLANGE	4	
40	640078	640078	684124	640078	684124	684124	O RING	4	
42	686164	686164	686164	686164	686164	686164	BOLT	4	
42	631917	631917	631917	631917	631917	631917	WAVE WASHER	4	
44	804764	804764	804764	804764	804764	804764	SILENCER ASSY	1	
51	770582	770582	770582	770582	770582	770582	CUSHION	2	
52	7768K23	7768K23	7768K23	7768K23	7768K23	7768K23	CHECK VALVE	4	
53	45065K32	45065K32	45065K32	45065K32	45065K32	45065K32	TRUCK VALVE	4	
54	5220K139	5220K139	5220K139	5220K139	5220K139	5220K139	TEE CONNECTOR	2	
55	8359K16	8359K16	8359K16	8359K16	8359K16	8359K16	NYLON TUBING 5FT.	1	
56	4429K418	4429K418	4429K418	4429K418	4429K418	4429K418	BUSHING	2	
57	4429K354	4429K354	4429K354	4429K354	4429K354	4429K354	CROSS	1	
58	4568K191	4568K191	4568K191	4568K191	4568K191	4568K191	NIPPLE	1	
59	48935K35	48935K35	48935K35	48935K35	48935K35	48935K35	VACUUM RELIEF VALVE	1	
KIT	K80-MC	K80-MN	K80-ME	K80-MH	K80-MS	K80-MV	LIQUID SIDE KIT		
KIT	K80-AM						AIR MOTOR KIT		

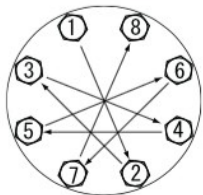

Tightening torque for center rod and out chambers.

Center Rod 43 ft-lbf {60 N-m}
Out Chambers 29 ft-lbf {40 N-m}

Tightening torque for manifold retainer bolts.

BFC/E/H/N/S/V 18 ft-lbf {25 N-m}

General Tools:

- Socket wrenches - 13mm, 17mm, 19mm, 24mm
- Hexagonal box wrench - 5mm, 6mm
- Small crowbars - 2
- Open-end wrenches - 24mm
- Plastic hammer

Special Tools (sold separately):

- Sleeve remover (713180).

Miscellaneous:

- Turbine oil Class 1 (equivalent ISO VG32 grade)
- Nuts - M16 x 1.5
- Thread locker
- Urea grease grade (NLGI) No. 2

Customer Notes	
Model #:	_____
Description:	_____
Serial #:	_____
Date Installed:	_____
Department Location:	_____
Tag/Project:	_____